



Proposed Development On-Site Noticing FOR LARGE-SCALE DEVELOPMENT PROJECTS PLANNING SERVICES DIVISION

Introduction

Pursuant to the “Sunshine Ordinance” (Ordinance No. 6417), adopted by City Council on August 15, 2017, any large-scale development project in the City shall have a project information sign notifying the public of the proposed project (an “On-Site Noticing Sign”). The project applicant shall fabricate and install the On-Site Noticing Sign in a location visible to pedestrians and motorists passing by the proposed project. Large-scale development projects are defined by the Sunshine Ordinance as those involving General Plan Amendments, a zoning reclassification intended to facilitate a change in land use, a residential development of more than 10 units, a hotel project containing more than 50 new rooms, commercial or industrial developments containing over 10,000 square feet adjacent to residential or other potentially sensitive land uses, and others subject to the Planning and Building Department Director’s discretion.

Procedures

Installation and Approval: Upon approval by the City, an On-Site Noticing Sign must be installed by the project applicant within 60 days of filing a development application. Appendices A & B depict the required design specifications for On-Site Noticing Signs. The applicant shall submit a signed Declaration of Posting accompanied by either a photo of installation or professional sign rendering in-person, via certified mail, or email to the project planner. The Declaration of Posting, (Appendix C) shall serve as proof of installation and must be submitted by the applicant.

Replacement: The applicant shall be responsible for replacing any sign that is missing, damaged, or vandalized upon request of the City.

Removal: The applicant must remove the On-Site Noticing Sign within 10 working days of a final decision on the proposed project. Appealed projects require removal of the On-Site Noticing Sign within 10 working days of an appeal decision.

Advertising Approved Projects: If the project is granted approval, the applicant may advertise the new development with a temporary sign subject to Anaheim Municipal Code Section 18.44.200 (Temporary Signs for Future Establishments).



Proposed Development On-Site Noticing

FOR LARGE-SCALE DEVELOPMENT PROJECTS
PLANNING SERVICES DIVISION

APPENDIX A – ON-SITE NOTICING SIGN DESIGN SPECIFICATIONS

HEIGHT

- MAXIMUM SIX (6) FEET HEIGHT FOR POST OR FENCE MOUNTED SIGNS
 - Height is measured as the distance from the top of the sign structure including all ornamentation and supports to the existing grade beneath the sign
 - Signs exceeding 6 feet in height require a [Sign Permit Application](#)

FOUNDATION / MOUNTING

- DOUBLE POST MOUNTED SIGNS
 - 4" x 4" wood posts with MPB44Z bracing set in 18" x 18" x 30" concrete footings
 - 4" diameter metal posts set 27" deep in 18" x 18" x 30" concrete footings
- FENCE MOUNTED SIGNS
 - A [Sign Permit Application](#) is required for fences over 6' in height
- WALL MOUNTED SIGNS
 - A [Sign Permit Application](#) is required

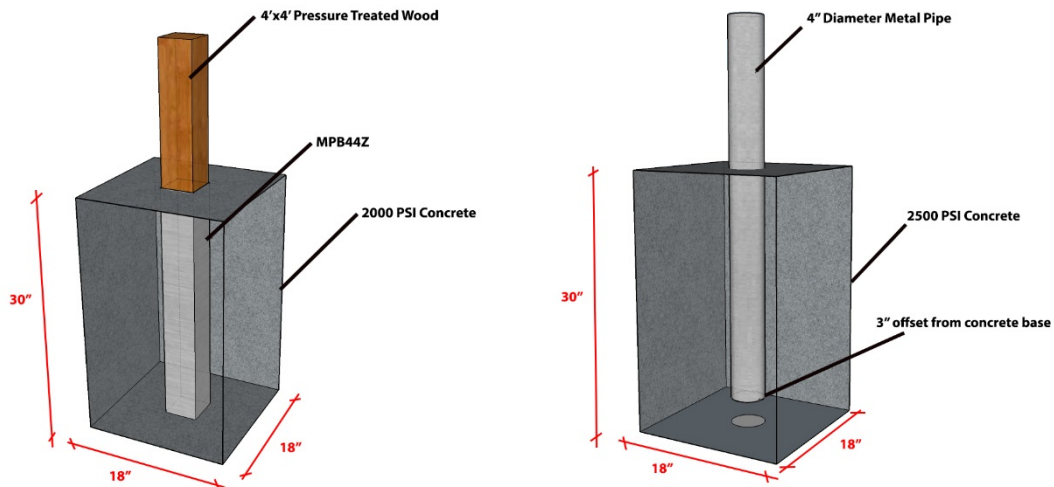

SIGN BOARD DIMENSIONS / SIZE

- FOUR FEET BY EIGHT FEET (4' X 8') OR AS APPROVED BY THE PLANNING AND BUILDING DEPARTMENT DIRECTOR OR DESIGNEE

MATERIALS

- CONSTRUCTED OF WOOD OR METAL



Proposed Development On-Site Noticing

FOR LARGE-SCALE DEVELOPMENT PROJECTS
PLANNING SERVICES DIVISION

LOCATION

- A MINIMUM OF ONE (1) SIGN ON EACH STREET FRONTAGE UNDER 600 FEET
- A MINIMUM OF TWO (2) SIGNS ON EACH STREET FRONTAGE OVER 600 FEET
- SIGN(S) MUST BE PLACED OUTSIDE THE LINE OF SIGHT

REQUIRED SIGN CONTENT

- "NOTICE OF PROJECT APPLICATION" MUST BE CONSPICUOUS
- PROJECT NAME
- PROJECT/CASE NUMBER(S)
- PROJECT DESCRIPTION
- PROJECT PLANNER
 - Name
 - Email
 - Phone Number
- PROJECT APPLICANT
 - Business Name
 - Applicant Name
 - Email
 - Phone Number
- COUNCIL DISTRICT NUMBER
- ADDITIONAL INFORMATION
 - "Additional project information, including any upcoming public meetings, may be obtained by contacting the staff noted below."
- QR CODE
 - "Up-to-date Project Information can also be found on GIS.ANAHEIM.NET/ANDYSMAP"

Please copy and place this
[QR Code \(download link\)](#)





Proposed Development On-Site Noticing
 FOR LARGE-SCALE DEVELOPMENT PROJECTS
 PLANNING SERVICES DIVISION

APPENDIX B – EXAMPLES & FIGURES

NOTICE
OF PROJECT APPLICATION

PROJECT NAME: CERRITOS AVENUE RESIDENTIAL SUBDIVISION

PROJECT NUMBER(S): Reclassification No. 2015-00280;
Conditional Use Permit No. 2015-05787;
Tentative Tract Map No. 17882

PROJECT DESCRIPTION: Proposed 12-lot residential subdivision.
Applicant is proposing to build 12 residences
ranging between 2,978 to 3,945 square feet
in size. The proposed lots range between 5,482
to 6,853 square feet in size (6,472 sq. ft. average).

Additional project information, including any upcoming public meetings, may be obtained by contacting the staff contact noted below.

CITY OF ANAHEIM
 PLANNING SERVICES DIVISION

STAFF CONTACT:
 JOHN DOE
 jdoe@anaheim.net
 714-765-5139
 www.anaheim.net



Up-to-date Project Information can also be found on GIS.ANAHEIM.NET/ANDYSMAP

PROJECT APPLICANT:
 DEVELOPMENT COMPANY - JANE DOE
 janedoe@devcomp.com
 714-555-5555

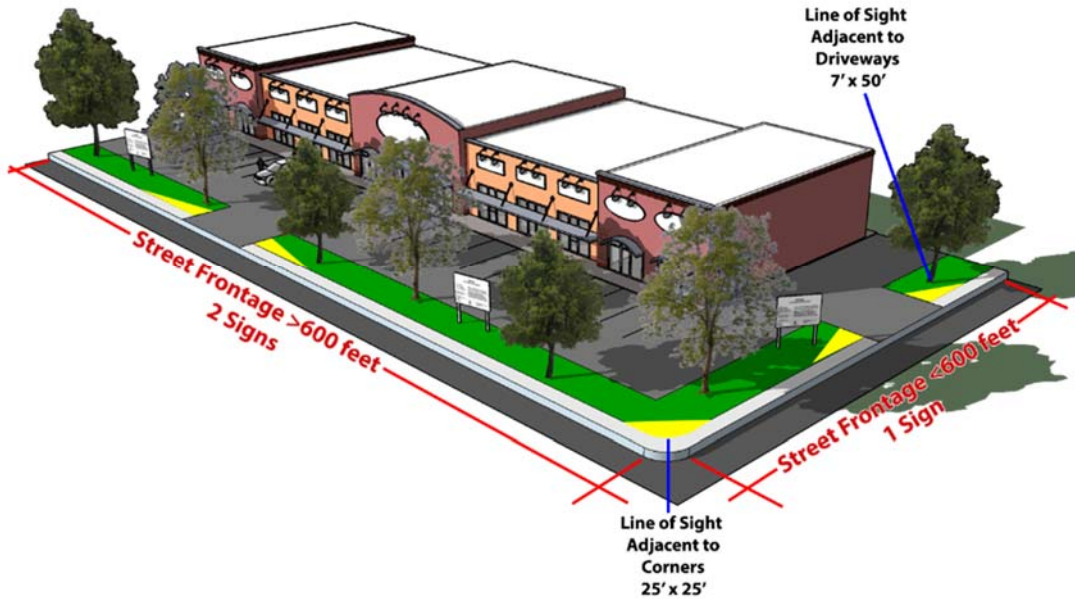



Proposed Development On-Site Noticing
FOR LARGE-SCALE DEVELOPMENT PROJECTS
PLANNING SERVICES DIVISION

APPENDIX C – DECLARATION OF POSTING

I, _____ do declare that:

1. I represent the project associated with the following Project Number(s):

2. On the date of execution of this declaration, I did personally and conspicuously post the NOTICE OF PROJECT APPLICATION on the project site.
3. This notice was posted in the time, form and manner as required by the Sunshine Ordinance on the date of execution of this declaration.

I declare under penalty of perjury, under the laws of the State of California that the foregoing is true and correct.

Date of Execution

Signature

Place Attached Photographic Proof of Posting or Professional Sign Rendering Below